

VME A32D32 Slave Controller

Description

The VMEbus was first standardized in 1981 and is still in wide use. With the advances in integration technologies, custom integrated VME controllers open the door for smaller and cheaper systems. Inicore offers a wide range of different VME slave controllers. Each one optimized for a certain application. The difference lies mainly in the address and data bus width and the supported data modes.

The VME slave controller shields all the complexity of the asynchronous VMEbus and provides an easy-to-use, synchronous parallel user side interface towards custom logic. A built-in interrupter handles all local interrupt requests and acknowledgments.

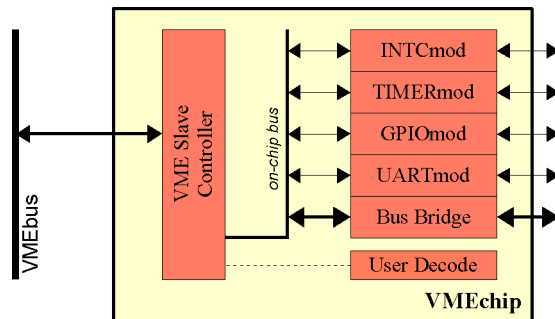

Figure 1: Sample application

The figure above illustrates a typical application where several peripheral functions together with the VME slave core as well as a bus bridge are integrated into one FPGA.

Supported modes

- Data modes: D8, D16, D32
- Address modes: A16, A24, A32
- Access modes: Read, write, read-modify-write
- Interrupter: D8, D16, D32, RORA, ROAK

Features

- ANSI/VITA 1-1994 compliant
- VME slave controller
- Data modes: D8, D16, D32
- Address modes: A16, A24, A32
- Supports read, write, read-modify-write
- Configurable D8, D16 or D32 interrupter
- Fully synchronous user side interface
- User selectable wait-states
- Synchronous design

Applications

- Industrial control
- Military
- Aerospace
- Telecom
- Medical

Utilization Table Optimized for Actel Devices

Family	Device - (speed grade)	Utilization				
		s-mod	c-mod	Tiles	RAM	Total
ProASIC ^{PLUS}	APA150			477		4%
Axcelerator	AX500-3	193	159			4%
SXA	SX72A-3	193	163			6%

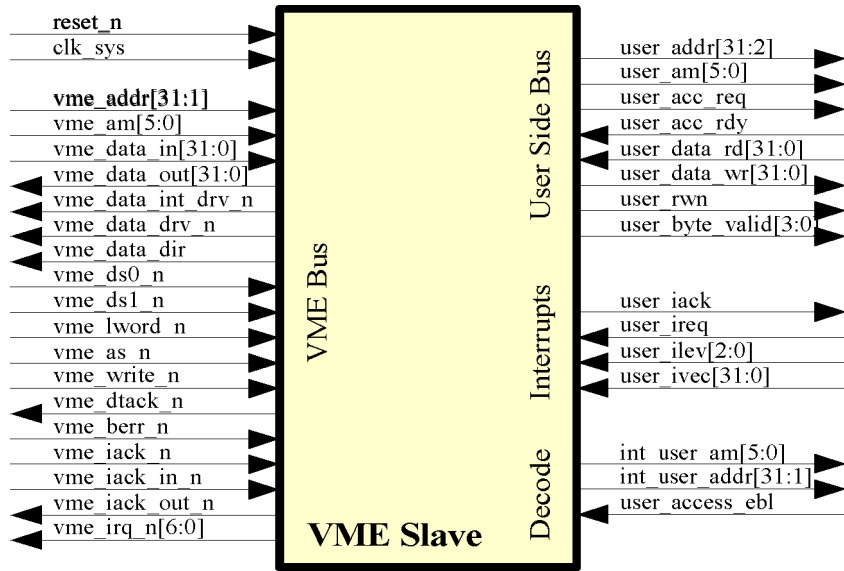

Figure 2: Symbol

Interfaces

Pin Name	Type	Description
Global Signals		
clk	in	System clock
reset_n	in	Asynchronous system reset, active low
VME Bus		
vme_addr[31:1]	in	Address bus
vme_am[5:0]	in	Address modifier code
vme_data_in[31:0]	in	Data bus input
vme_data_out [31:0]	out	Data bus output
vme_int_drv_n	out	Internal i/o driver enable
vme_data_drv_n	out	External data bus driver enable
vme_data_dir	out	External data bus driver direction
vme_ds0_n	in	Data strobe 0
vme_ds1_n	in	Data strobe 1
vme_lword_n	in	Long word indicator
vme_as_n	in	Address strobe
vme_write_n	in	Read write not indicator
vme_dtack_n	out	Data acknowledge
vme_berr_n	in	Bus error
vme_iack_n	in	Interrupt acknowledge
vme_iack_in_n	in	Interrupt acknowledge chain in

Pin Name	Type	Description
vme_iack_out_n	out	Interrupt acknowledge chain out
vme_irq_n[6:0]	out	Interrupt request
User Side Bus		
user_addr[31:2]	out	Address bus
user_am[5:0]	out	Address modifier code
user_acc_req	out	Data access request
user_acc_rdy	in	Data access request ready
user_data_rd[31:0]	in	Data read bus
user_data_wr[31:0]	out	Data write bus
user_rwn	out	Data read or write access
user_byte_valid [3:0]	out	Data byte valid
User Decode		
int_user_addr[31:1]	out	Address bus
int_user_am[5:0]	out	Address modifier code
user_access_ebl	in	Valid user access
Interrupt		
user_iack	out	Interrupt acknowledge
user_ireq	in	Interrupt request
user_ivec[31:0]	in	Interrupt vector
user_ilevel[2:0]	in	Interrupt request level

About Inicore

- ◆ FPGA and ASIC Design
- ◆ Easy-to-use IP Cores
- ◆ System-on-Chip Solutions
- ◆ Consulting Services
- ◆ ASIC to FPGA Migration
- ◆ Obsolete ASIC Replacements

Inicore is an experienced system design house providing FPGA / ASIC and SoC design services. The company's expertise in architecture, intellectual property, methodology and tool handling provides a complete design environment that helps customers shorten their design cycle and speed time to market. Our offering covers feasibility study, concept analysis, architecture definition, code generation and implementation. When ready, we deliver you a FPGA or take your design to an ASIC provider, whatever is more suitable for your unique solution.

Deliverables

The core is available as Actel optimized netlist or as RTL version.

Actel Optimized Netlist:

- Netlist for target FPGA, EDIF, Verilog and VHDL format
- User Guide

RTL Source Code:

- VHDL or Verilog source code
- Functional verification testbench
- Synthesis script
- Timing constraints
- User guide

© 2002, Inicore Inc, All rights reserved.
All brands or product names mentioned are the property of their respective holders.

51410.71.01 Dec/2002